

**Always Ahead**

# VTURN A200/A260

- *One-piece slant bed*
- *Shortened belt driven spindle with C-axis and Y-axis available*
- *Digital Tailstock*
- *DDS built-in spindle and subspindle available*
- *Servo turret with high thrust force*
- *Box slideways with high rapid feed 24 m/min*
- *Rotary operation panel*



**Victor Taichung - an established ISO 9001, 14001 & 45001 company**



# Ahead of Performance

## Vturn-A200/A260 Turning Center

- One piece 30° slant bed with large swing diameter
- 8" Power chuck / 4200 rpm (A200)  
10" Power chuck / 3500 rpm (A260)
- Z-axis travel 600 mm (A200) / 750 mm (A260)
- High thrust force by small pitch ballscrew
- High rapid feed 24 m/min (Z-axis)
- Shortened belt driven spindle
- Digital tailstock

### Spindle 12 KW (A200) / 22 KW (A260)

- 8" chuck / 4200 rpm (A200), 10" chuck / 3500 rpm (A260)
- Spindle output 245 Nm (A200, S3-15%) / 574 Nm (A260, S3-25%)
- Low base speed 350 rpm (A200) / 307 rpm (A260)
- NN type (roller type) bearings
- Shortened belt length
- Victor Taichung's own spindle

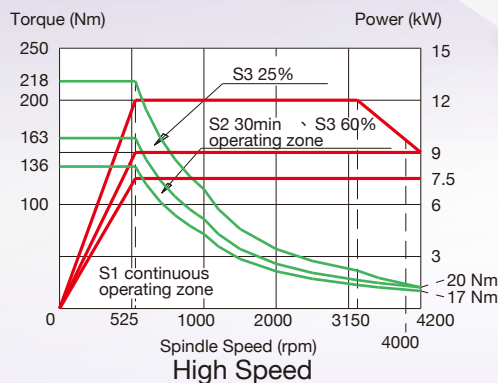
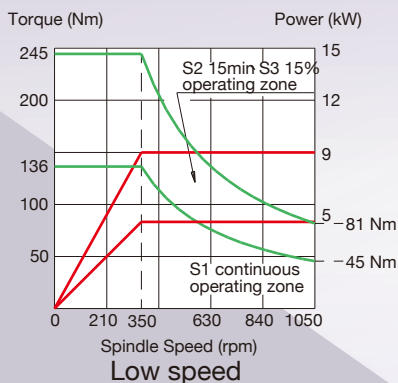
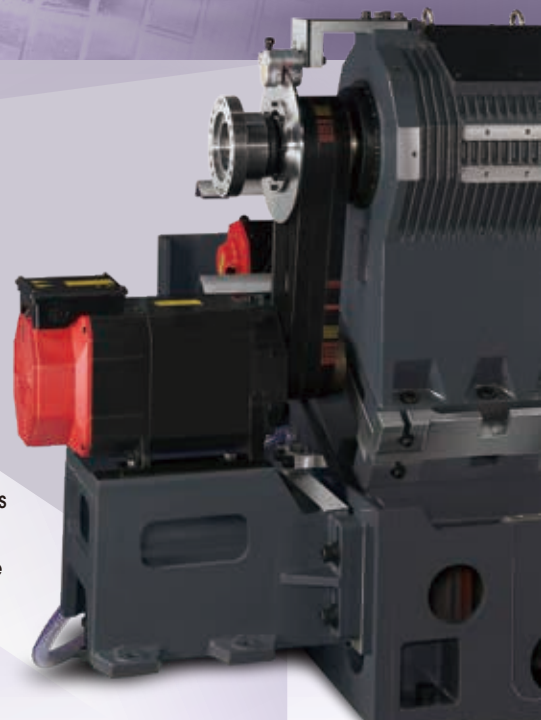

**Conventional design  
with much longer belts**

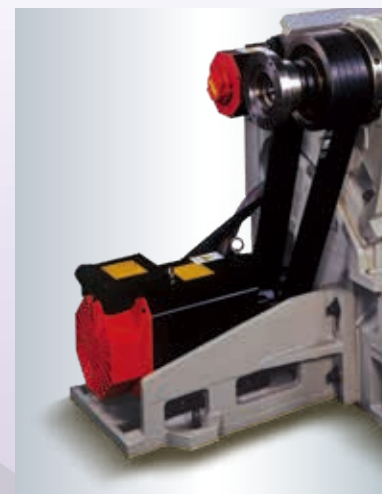
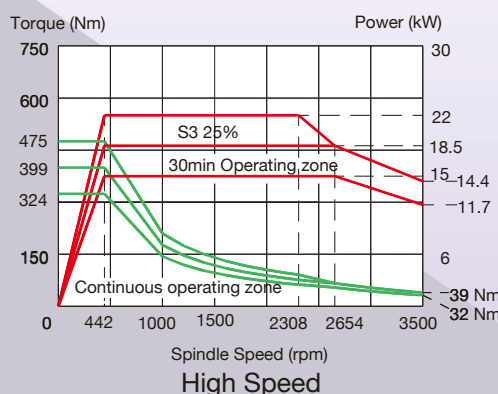
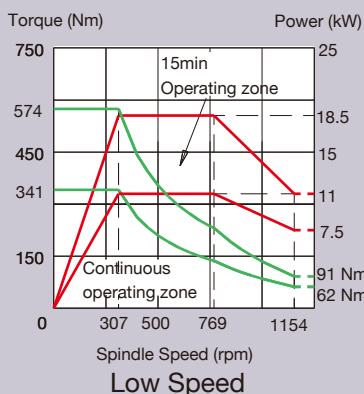



Vturn-A260

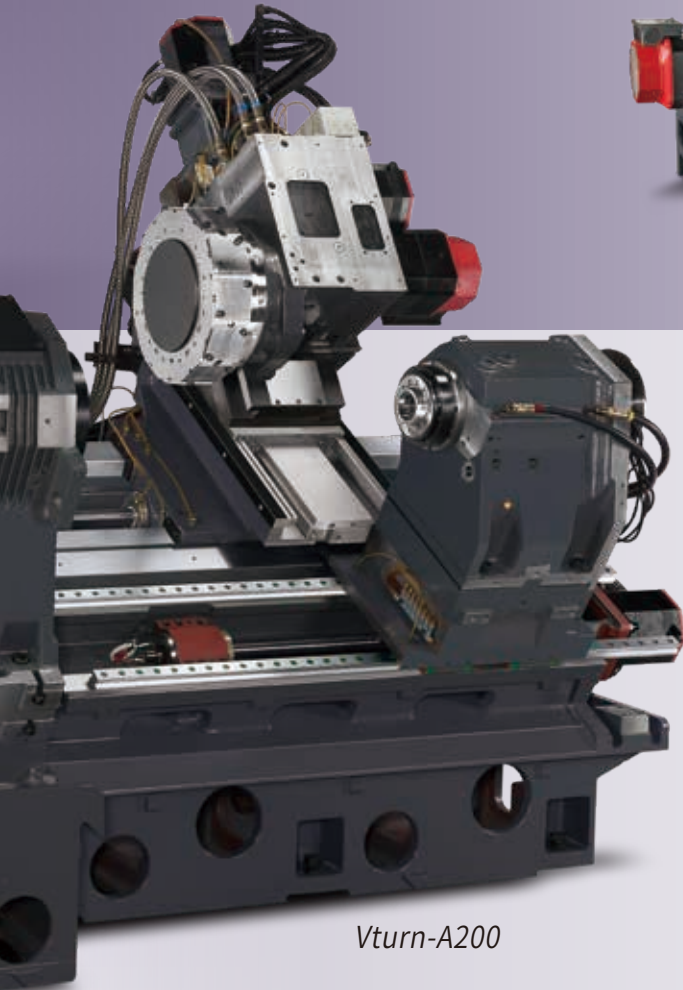

Vturn-A200



## Servo Turret 1.0 sec. (adjacent tools)

- Victor Taichung's own turret
- Turret indexing time 1.0 sec (adj.), 1.45 (opposite)



Certificated Casting

**GA350**

## Box Slideways (X/Z)

- 65/80 mm for Vturn-A200  
85/90 mm for Vturn-A260
- Victor Taichung's own casting



## Digital Tailstock

- NC tailstock (driven by E-axis servo motor)
- MT-4 (A200) / MT-5 (A260) without built-in bearing
- Quick moving and positioning without stroke detection
- Victor's GUI with guidance
- Opt. Subspindle available to complete a part in one set-up

# Ahead of Performance

## C-axis & Y-axis Application

- *Optional C-axis by belt-driven spindle or by built-in spindle*
- *Belt-driven spindle good for drilling/milling*
- *Built-in DDS spindle good for contour milling*
- *Available with subspindle (opt.)*

### (opt.) DDS Spindle 18.5 KW (A200, S3-15%) / 22 KW (A260, S3-25%)

- 5000 rpm / 8" chuck (A200), 3500 rpm / 10" chuck (A260)
- Good for contour milling
- Spindle output 478 Nm (A200, S3-15%) / 433 Nm (A260, S3-25%)
- Low base speed 370 rpm (A200) / 485 rpm (A260)
- NN type (roller type) bearings

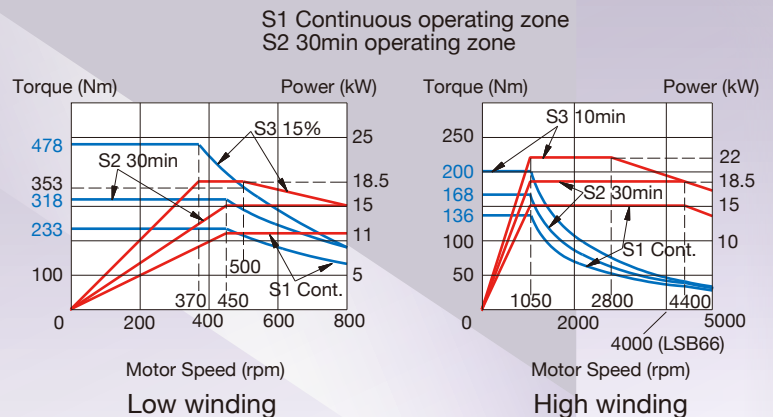
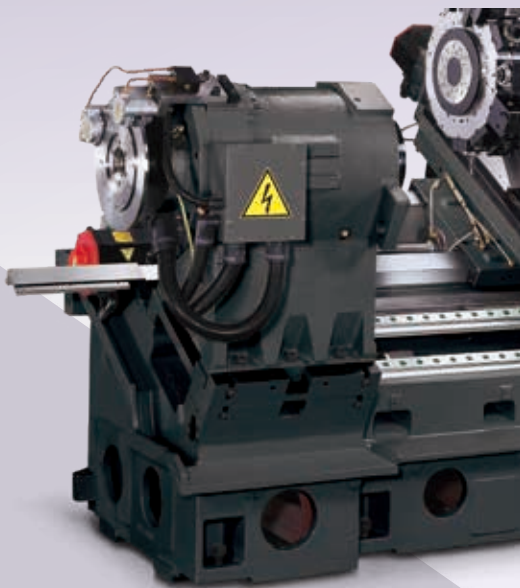

**Fanuc Bil 180M (A200)**

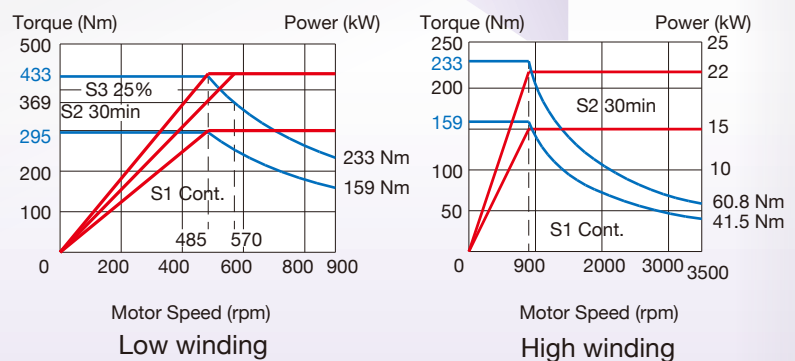

**Fanuc Bil 200M (A260)**

## Milling tests on Aluminum parts

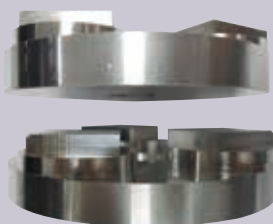

**Belt-driven spindle**



**Built-in spindle**





## BMT-55/65 Milling Turret

- 12 stations live tools (opt. half indexing 24 stations)
- Milling power 7.5 kW (S3-15%) for A200, 11kW (S3-15%) for A260
- Milling speed 4000 rpm (opt. 6000 rpm)

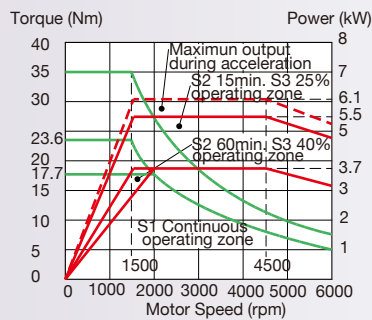

A200 (BMT-55)

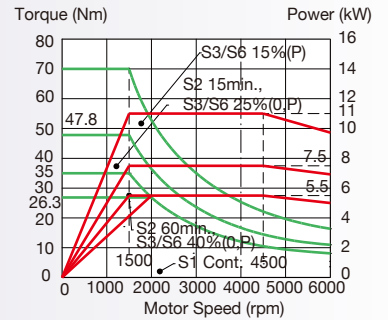

A260 (BMT-65)

## Subspindle 11 KW (A200) / 15 KW (A260) (S3-15%)



- DDS built-in spindle
- 5" chuck / 7000 rpm / 11 kW (A200)  
8" chuck / 5000 rpm / 15 kW (A260)
- Part changeover time: 20 sec.

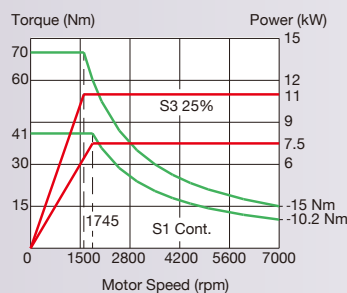

Fanuc Bil 112S (A200)

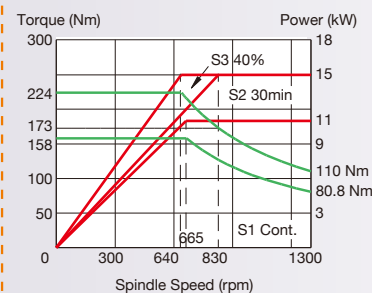

Low Winding

Fanuc Bil 170S (A260)

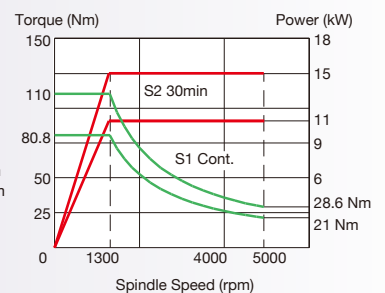

High Winding

# Standard and Options

- Fanuc Oi-TF Plus (type-1) control with 10.4" screen
- E-axis servo driven tailstock
- Pressure gauge in front
- Rotary operation panel
- Door moving along LM guideways
- Coolant flush onto Z-axis covers
- Built-in LED light
- Chip conveyor



Chip conveyor (std.)

Coolant flush (std.)



## Tooling accessories (excl. BMT turret model)

Tools \ Model	Vturn-A200	Vturn-A260
Tool shank for turret disk	20 mm (3/4")	25 mm (1")
Maximum boring bar Dia,	40 mm (1 1/2")	50 mm (2")
Face + OD cutting tool holder	1	1
Face + ID. cutting tool holder	1	1
<b>Boring bar holder</b>		
32 mm (1 1/4")	6	-
40 mm (1 1/2")	-	6
50 mm (2")	-	1
<b>Boring bar sleeve</b>		
8 mm (5/16")	1	1
10 mm (3/8")	2	2
12 mm (1/2")	2	2
16 mm (5/8")	2	2
20 mm (3/4")	2	2
25 mm (1")	2	2
32 mm (1 1/4")	-	2
40 mm (1 1/2")	-	-
<b>Drill socket</b>		
MT1	Opt.	-
MT2	1	1
MT3	Opt.	1
MT4	-	1
<b>'U' Drill holder</b>		
20 mm (3/4")	Opt.	Opt.
25 mm (1")	1	1
32 mm (1 1/4")	-	1

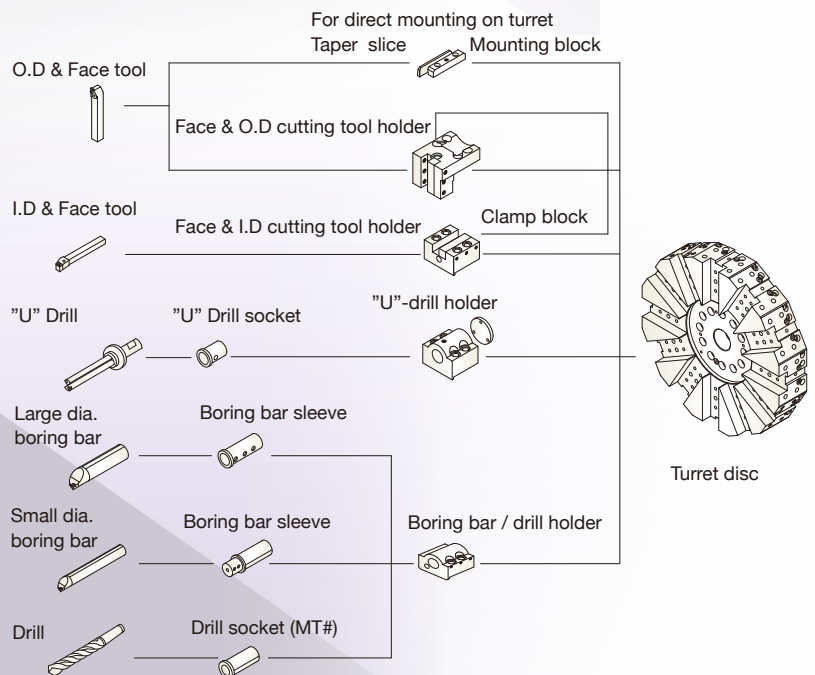

# C-axis Application

## Bolt Mounted Milling Turret BMT-55/65 Turret

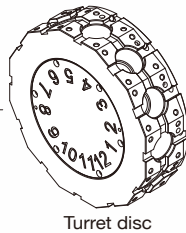
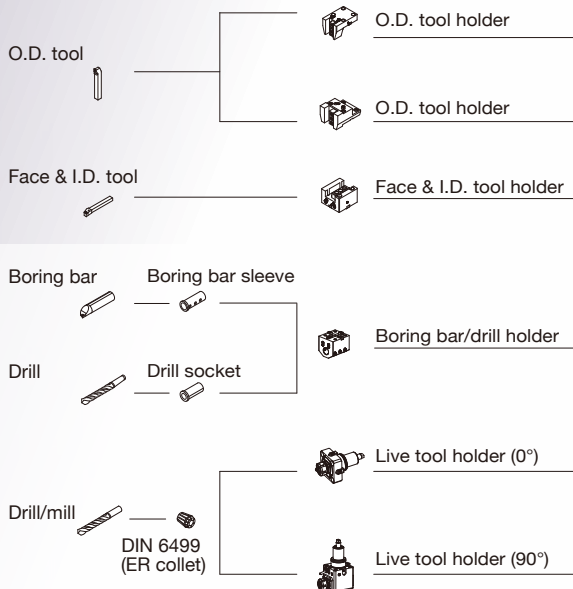

### BMT-55 (Vturn-A200)

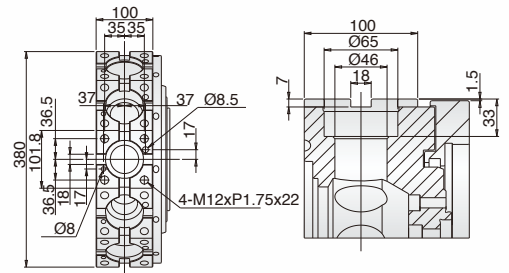

### BMT-65 (Vturn-A260)

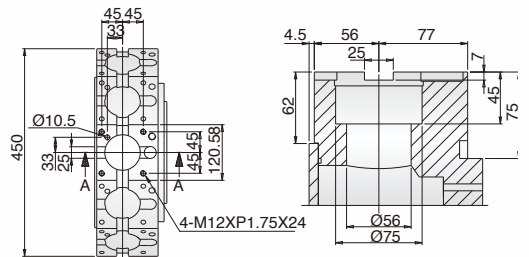

Unit: mm

Tool presetter (opt.)



Oil skimmer (opt.)



Part catcher (opt.)



## Machine Color Option



Standard



RAL-7024







## Vturn-A260

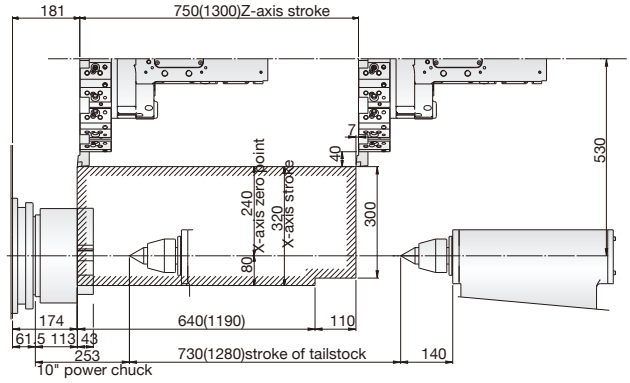
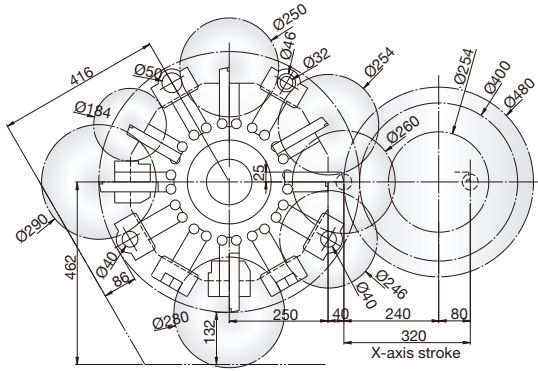

## Vturn-A260(Y)(S)CM (BMT-65, 12 stations)

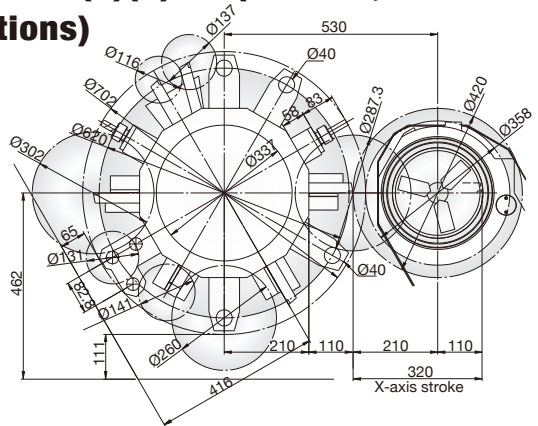

## Vturn-A260CM or YCM

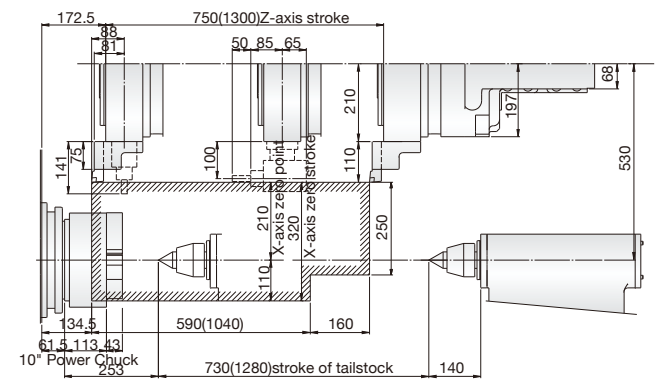

## Y-axis travel

BMT-65  
(12 tools)

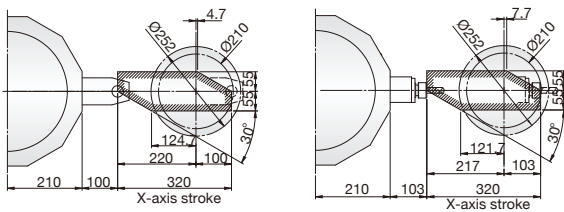

BMT-55  
(16 tools)

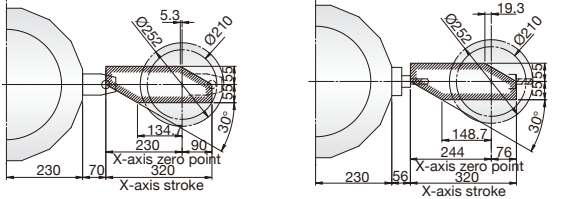

## Vturn-A260SCM or YSCM (12 stations)

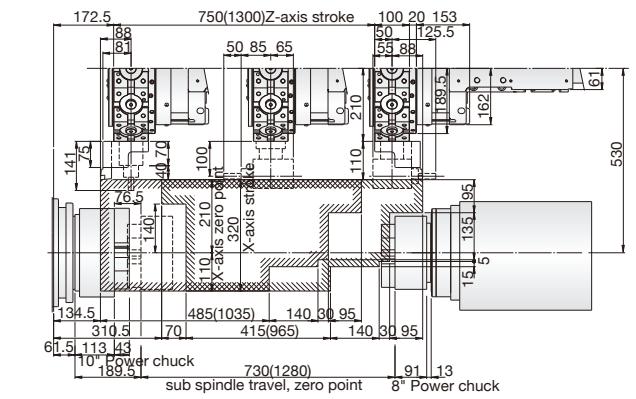

## Vturn-YSCM (BMT-55, 16 stations)

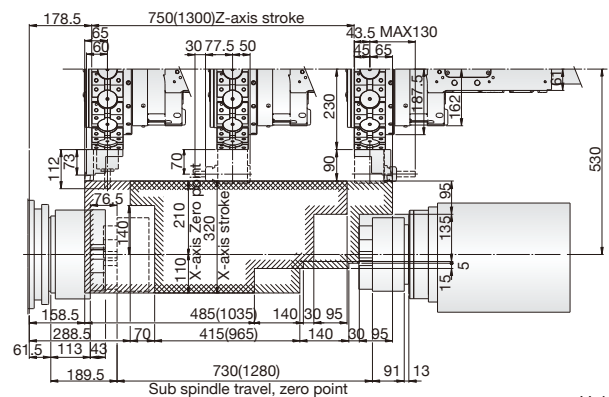
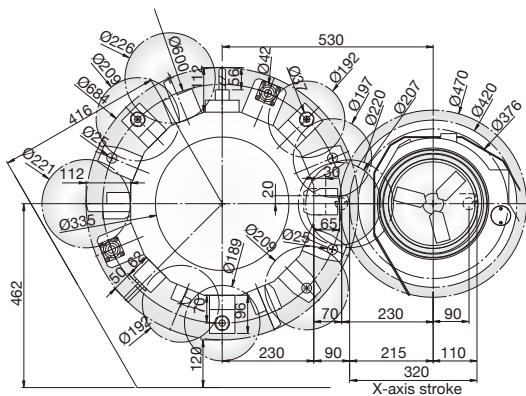

Unit: mm

# Machine Layout

## Vturn-A200[Y]

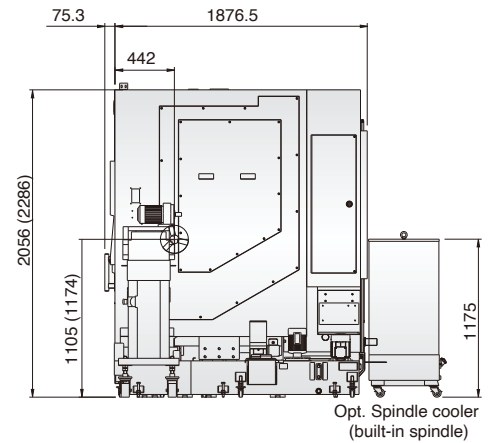
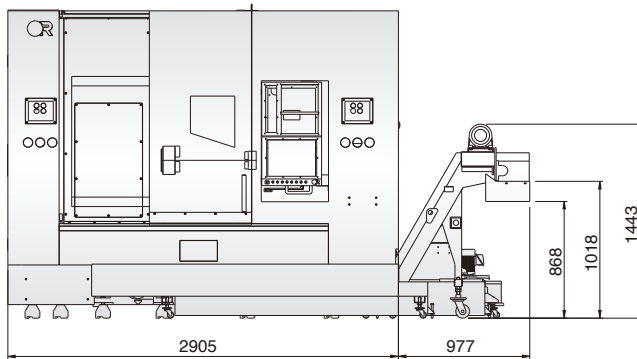
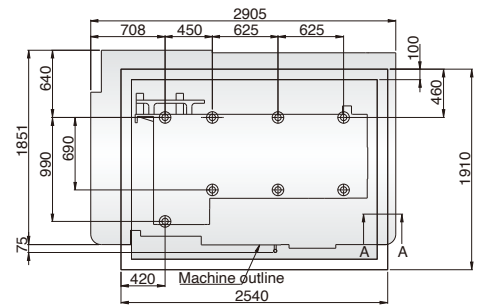
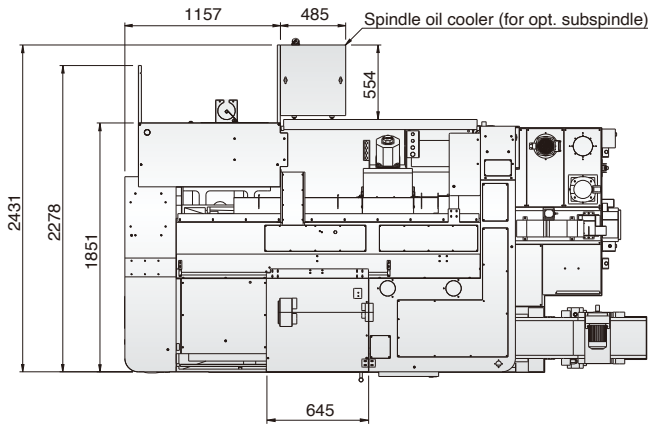

Unit: mm

## Vturn-A260[Y]

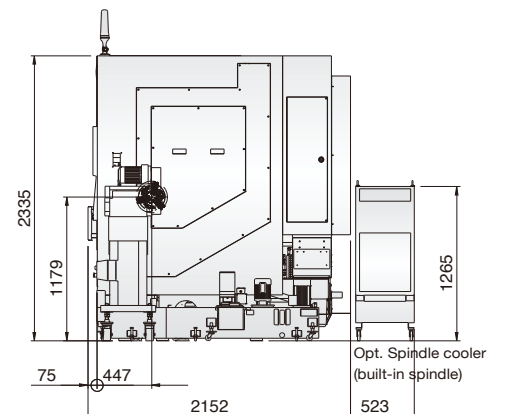
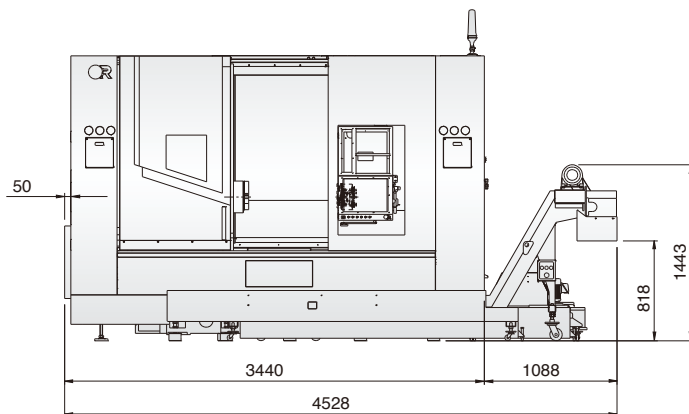
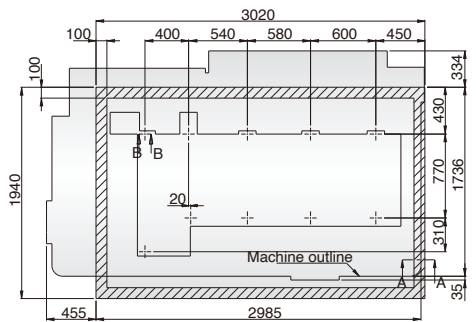
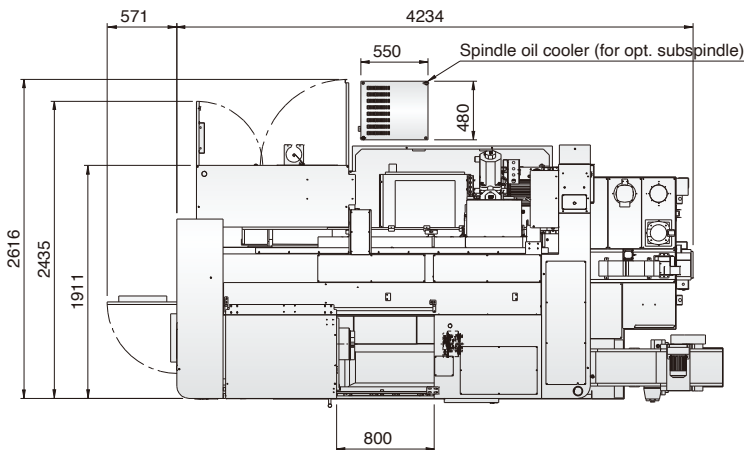

Unit: mm

# Machine Specification

Item \ Model	Unit	Vturn-A200 (SM)	Vturn-A200CM (SCM) Vturn-A200YCM (YSCM)	Vturn-A260 (SM)	Vturn-A260 (S) CM Vturn-A260Y (S) CM	
Capacity	Swing over bed	mm	750	830 (limited by front door)	800 (limited by front door)	800 (limited by front door)
	Swing over carriage	mm	555	720	620	770
	Between centers	mm	604	604	910 (950)	910 (950)
	Max. turning dia.	mm	390 (330)	330	480	420
	Std. Turning dia.	mm	320 (286)	286	400 (358)	358
	Bar capacity	mm	52 (opt. 66)	52 (opt. 66)	75 (opt. 91 LSB)	75 (opt. 91 LSB)
Axis Feeds	X axis travel	mm	195+20 (165+50)	165+50 (165+50)	240+80 (210+110)	210+110 (210+110)
	Z axis travel	mm	600	600	750	750
	E axis travel (subspindle)	mm	- (550)	- (550)	- (730)	- (730)
	Y axis travel	mm	-	±45	-	±55
	Rapid feedrate	m/min	X/Z: 24/24 (E: 15)	X/Z: 24/24, Y: 10 (E: 15)	X/Z: 18/24 (E: 15)	X/Z: 18/24, Y: 10 (E: 15)
	Feed servo motor	KW	X: 3, Z: 4 (E: 2.5)	X: 3, Z: 4, Y: 3 (E: 2.5)	X: 4, Z: 4 (E: 2.5)	X: 4, Z: 4, Y: 4 (E: 2.5)
	JOG feedrate	mm/min	X/Z=0~1260	X/Z=0~1260	X/Z=0~1260	X/Z=0~1260
Spindle	Ballscrew dia. x pitch	mm	Ø32×P6 (X), Ø40×P8 (Z) Ø40×P8 (E)	Ø32×P6 (X), Ø40×P8 (Z) Ø32×P6 (Y), Ø40×P8 (E)	Ø36×P6 (X), Ø50×P8 (Z) Ø40×P8 (E)	Ø36×P6 (X), Ø50×P8 (Z) Ø32×P6 (Y), Ø40×P8 (E)
	Max. spindle speed	rpm	4200 (belt-driven)	4200 (belt-driven)	3500 (belt-driven)	3500 (belt-driven)
	Spindle nose (chuck)	Inch	A2-6 (8")	A2-6 (8")	A2-8 (10")	A2-8 (10")
	Spindle bore	mm	62 (opt. 76)	62 (opt. 76)	87 (opt. 105 LSB)	87 (opt. 105 LSB)
	Spindle motor (cont./30min)	KW	7.5/9 (αiIP15) opt. 11/15 (αiIP22)	7.5/9 (αiIP15) opt. 11/15 (αiIP22) opt. 15/18.5 (βiI180M) DDS	15/18.5 (αiIP30) opt. 18.5/22 (αiIP40)	15/18.5 (αiIP30) opt. 18.5/22 (αiIP40) opt. 15/22 (βiI200M) DDS
	Bearing inside dia.	mm	100 (opt. 110)	100 (opt. 110)	130 (opt. 160 LSB)	130 (opt. 160 LSB)
Subspindle (E axis)	Max. spindle speed	rpm	7000 (built-in)	7000 (built-in)	4200 (built-in)	4200 (built-in)
	Spindle nose (chuck)	inch	A2-5 (5")	A2-5 (5")	A2-6 (8")	A2-6 (8")
	Spindle motor (cont./25%)	KW	7.5/11 (βiI112S)	7.5/11 (βiI112S)	11/15 (βiI170S)	11/15 (βiI170S)
	Bearing Inside dia.	mm	75	75	100	100
	Spindle bore	mm	42	42	62	62
	Bar capacity	mm	30	30	52	52
Turret	No. of tools	no.	12	12	12	12
	No. of live tools	no.	-	12 (DIN 1809)	-	12 (DIN 1809), opt. 16
	Tool shank size	mm	20 (opt. 25)	20 (opt. 25)	25	25
	Max. boring bar dia.	mm	Ø40 (BMT-55)	Ø40 (BMT-55)	Ø50 (BMT-65)	Ø50 (BMT-65) opt. Ø40 (BMT-55)
	Exchange time (T-T)	sec	0.3	0.3	0.3	0.3
	Exchange time (including disk up & down)	sec	1.04 (Adjacent) 1.45 (opposite)	1.04 (Adjacent) 1.45 (opposite)	1.04 (Adjacent) 1.45 (opposite)	1.04 (Adjacent) 1.45 (opposite)
Tailstock	Milling speed	rpm	-	4000 (opt. 6000)	-	4000 (opt. 6000)
	Milling motor (cont./15%)	KW	-	3.7/7.5 (βiI3_12000)	-	5.5/11
	Quill diameter	mm	N.A. (digital)	N.A. (digital)	N.A. (digital)	N.A. (digital)
	Quill taper		MT#4	MT#4	MT#5	MT#5
	Stroke (E-axis)	mm	550	550	730	730
	Positioning accuracy (bi-directional)	mm	0.01	0.01	0.01	0.01
Accuracy	Repeatability	mm	±0.004	±0.004	±0.004	±0.004
	Coolant tank capacity	L.	330	330	360	360
Machine	NC controller	Fanuc	0i-TF Plus (10.4")	0i-TF Plus (10.4")	0i-TF Plus (10.4")	0i-TF Plus (10.4")
	Power requirement	KVA	21 (29)	25 (35) 26 (36)	31 (44)	38 (50) 39 (51)
	L×W×H (with chip conveyor)	mm	3882 x 2430 x 2056	3882 x 2430 x 2056	4528 x 2152 x 2335	4528 x 2152 x 2335
	Net weight	kg	6500 (6700)	6500 (6700) 6800 (7000)	7000 (7200)	7000 (7200) 7300 (7500)

\* Machine and controller specifications are subject to change without notice.

## Standard Accessories:

- Fanuc 0iTF Plus (10.4", type-1) control
- Power chuck with soft jaws
- Digital tailstock (E-axis driven)
- Chip conveyor with cart
- Fully enclosed splash guarding
- Hand-wheel
- Tool holders (excl. VDI/BMT turret)
- Coolant flush on Z-axis cover
- 3 step warning light
- Fanuc e-book (CD)

## Optional Accessories:

- Air conditioner for electrical cabinet
- Manual tool presetter (Renishaw®)
- Auto tool presetter (Renishaw®)
- Parts catcher (swing type)
- KITAGAWA® hydraulic chuck
- Auto door
- Bar feeder interface

- Air blow system
- Higher pressure coolants
- Oil skimmer
- Sub-spindle (direct drive)
- Large spindle bore
- Fanuc manuals
- Hard jaws
- Handy handwheel (remote MPG)

# VICTOR Taichung's FANUC Oi-TF Plus 10.4" Control (Type I) Specifications

## Standard

ITEM/SPECIFICATION	DESCRIPTION
<b>Controlled Axes:</b>	
1. Controlled axes	2 Axes (X, Z)
2. Simultaneous controlled axes	2 Axes
3. Least input increment	0.001mm
4. Least command increment	0.0005mm (X) / 0.001mm (Z)
5. Command system	Incremental / Absolute
6. HRV Control	HRV3+
7. Unexpected disturbance torque detection (AIR-BAG)	Std.
8. Backlash compensation	Std.
9. Stored pitch error compensation	Std.
<b>Operation &amp; Program Input:</b>	
1. Input / Output interface	RS-232, PCMCIA Card, USB
2. Tool offset	99 sets
3. Sequence number	N5-Digit
4. Program number	O8-Digit
5. Program name	31-characters
6. M code function	M3-digit
7. S code function	S4-digit
8. T code function	T4-digit
9. Positioning	G00
10. Linear interpolation	G01
11. Circular interpolation	G02, G03
12. Programmable data input	G10
13. Plane selection	G17-G19
14. Inch / Metric conversion	G20 / G21
15. Reference position return	G28, G30
16. Thread cutting	G32, G34
17. Threading retract	Std.
18. Tool nose radius compensation	G40-G42
19. Work piece coordinate system	G52-G59
20. Macro, Sub program call	G65, M98, M99 (10 folds nested)
21. Multiple repetitive cycle I & II	G70-G76
22. Canned cycle for drilling	G80-G89
23. Canned cycles	G90, G92, G94
24. Program stop / end	M00-M02 / M30
25. Rigid tapping (Spindle)	M29
26. Manual Guide i	Std.
27. Optional blocks skip 2-9	Std.

## Feed Function:

1. Manual handle feed rate	X1, X10, X100
2. Rapid traverse rate	F0, 25%, 50%, 100%
3. Cutting feed rate	0-150%
4. Spindle override	50-120%
5. Feed per Minute / Revolution	G98 / G99

## Edit Operation:

1. Part Program Storage Length (in total)	5120m (2MB)
2. Number of Registerable programs (in total)	1000
3. Part Program Editing	Std.
4. Memory card program entry count extension (Max. 1000)	Std.

## C Axis Function:

1. Polar coordinate interpolation	Std. (G112/G113)
2. Cylindrical interpolation	Std. (G107)
3. CS contouring control	Std.
4. Coordinate System Rotation	Std.

## OPTIONS

### With hardware included

1. Tool life management	<input type="checkbox"/>
2. Program restart	<input type="checkbox"/>
3. Data server (with PCB and CF card 1GB)	<input type="checkbox"/>
4. Ethernet/IP (to be linked to robot)	<input type="checkbox"/>
5. PROFIBUS-DP (to be linked to robot)	<input type="checkbox"/>
6. CC-Link (to be linked to robot)	<input type="checkbox"/>
7. Fast Ethernet (required for SCADA Web with additional RJ45 port)	<input type="checkbox"/>

### Without hardware included

8. Circular thread cutting (G35, G36)	<input type="checkbox"/>
9. AICC-1 (G5.1 Q1, 40 blocks)	<input type="checkbox"/>
10. AICC-2 (G5.1 Q1, 200 blocks)	<input type="checkbox"/>
11. Helical interpolation (C-axis only)	<input type="checkbox"/>
12. Arbitrary speed threading	<input type="checkbox"/>

## Spindle Motor Upgrade (opt.)

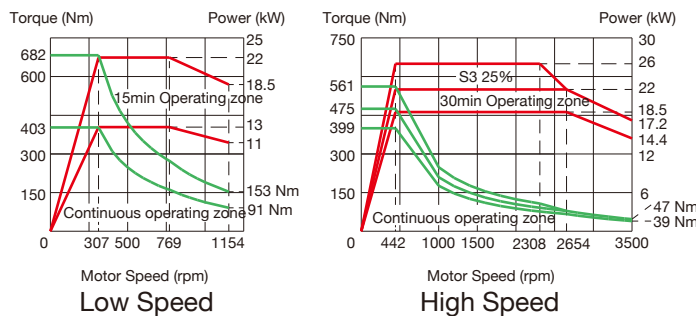
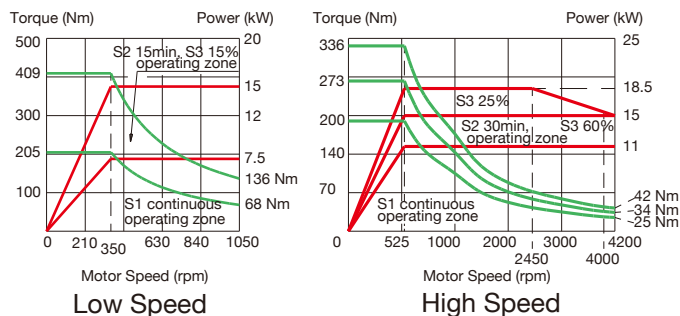

THE VICTOR-TAICHUNG COMPANIES

### TAIWAN

http://www.victortaichung.com

E-mail : info@mail.or.com.tw

Victor Taichung Machinery Works Co., Ltd.

No. 1, Jingke Central 2nd Rd.,

Nantun Dist., Taichung 40852,

TAIWAN, R.O.C.

TEL : 886-4-23592101

FAX : 886-4-23593389

### FRANCE

Victor France

TEL : 33-1-64772000

FAX : 33-1-64772063

### GERMANY

Victor GmbH

TEL : 49-2261-478434

FAX : 49-2261-478327

### SOUTH AFRICA

Victor Fortune (PTY) Ltd.

TEL : 27-11-3923800

FAX : 27-11-3923899

### MALAYSIA

Victor Machinery (M) SDN. BHD.

TEL : 60-3-56337180

FAX : 60-3-56337191

### THAILAND

Victor CNC (Thailand) Co., Ltd.

TEL : 66-2-9263735

FAX : 66-2-9032373

### INDONESIA

PT. Victor Machinery Indonesia

TEL : +62-21-88958504

FAX : +62-21-88958513

### USA

Fortune International Inc.

TEL : 1-732-2140700

FAX : 1-732-2140701

### CHINA

Victor Taichung

Machinery (Shanghai)

TEL : 86-21-59768018

FAX : 86-21-59768009



HTL



VTL



VMC



HMC



XMT



PIM